

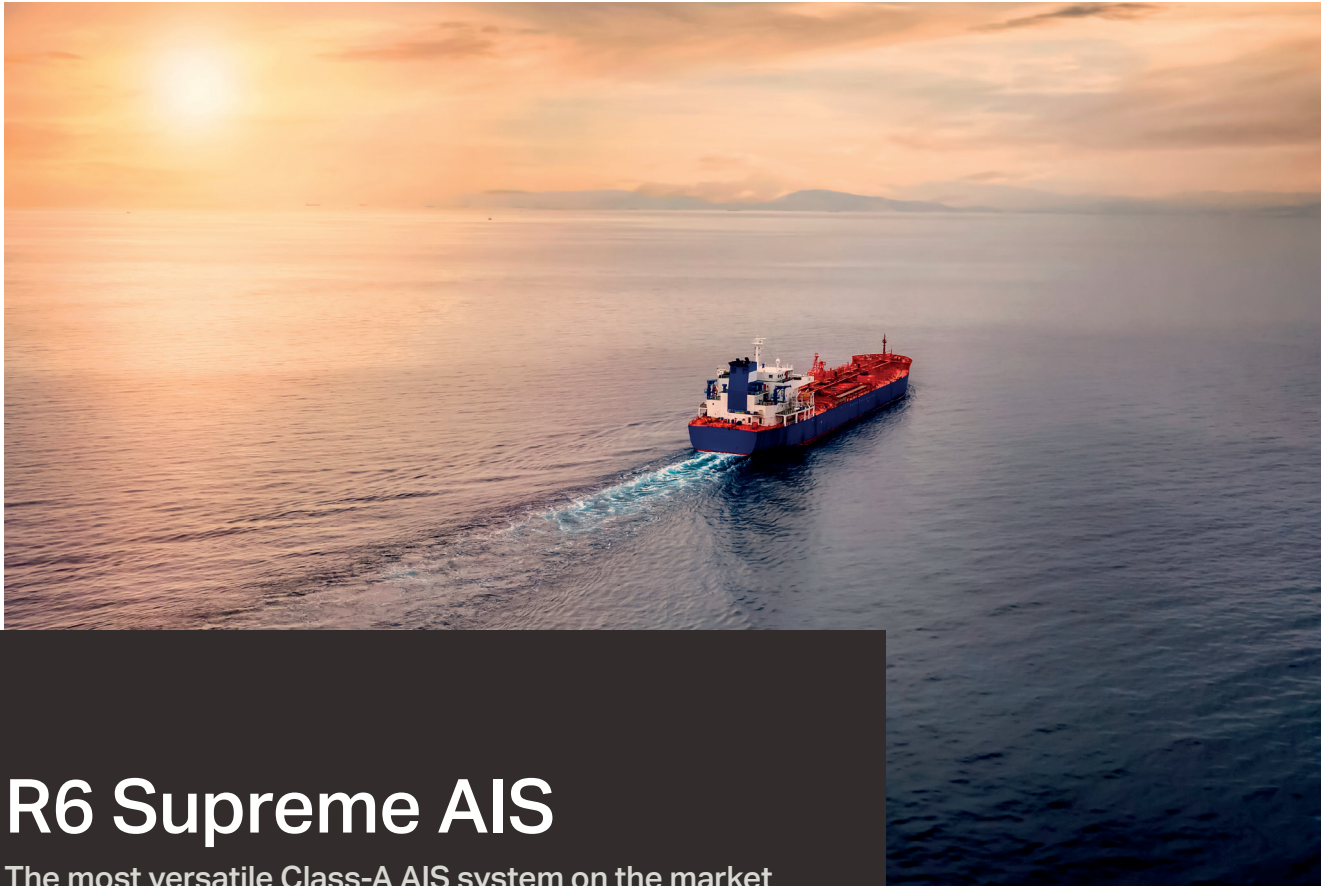

SAAB



R6 Supreme AIS

The most versatile Class-A AIS system on the market

The R6 Supreme system is the new generation of shipborne Class-A Transponder system that represents the pinnacle of innovation in the field of AIS technology. It is type approved for AIS and prepared for future VDES functionality with its new state-of-the-art Software Defined Radio providing an outstanding AIS sensitivity of -118 dBm. Designed and tested to IEC 61993-2 and future ITU-R M.2092-1 as applicable.

Easy to use

The R6 Supreme is intuitive and easy to operate and designed to be a tool for the daily work. It is equipped with an all-new Control and Display Unit (CDU), featuring a speedy modern graphical user interface (GUI) in a brilliant, sunlight readable 7-inch touch display with accurate colours at any viewing angle. The display has a resolution of 1024x600 pixels in more than 16M colours. The CDU has interface for central bridge equipment dimming.

All information is easy to access through a GUI that reminds of a modern smartphone.

Sensitivity

The R6 Supreme is equipped with a state-of-the-art Software Defined Radio that provides a "Best-In-Class" sensitivity that exceeds the international standards and provides an enhancement in terms of signal reception and range.



Dual use

The R6 Supreme can be integrated with a SAAB type approved Navigation GNSS receiver, and share the Control and Display Unit (CDU) to minimize the number of screens on the bridge and lower the cost for equipment and installation.

Future proof

In a truly innovative design, Saab has once again created a class leading AIS unit that goes well beyond any system previously on the market. The R6 Supreme meets the Class-A AIS radio requirements with ease. The R6 Radio is capable of handling 64 parallel receive or transmit processes allowing for reception and operation of AIS, ASM, AMRD, DSC and Secure AIS over all channels, in parallel regardless of bandwidth or if they are on the lower or upper band.

The R6 Supreme incorporates also the new Bridge Alarm Management (BAM) standard as well as dual LAN interfaces (IEC 61162-450) for efficient network integration into bridge systems.

Easy installation

The R6 Supreme AIS system can easily be integrated with other on-board systems such as ECDIS, radar or other display solutions using traditional NMEA serial communication or network interface. Dual network interfaces in both the transponder and CDU makes it simple to install on redundant bridge networks.

The R6 Supreme offers same VHF and GPS antenna interfaces as with the majority of other AIS equipment, which simplifies re-use of cabling when upgrading.

Features

- Best-in-Class with increased sensitivity (better than -118 dBm) and resilience to interference
- Meets SOLAS V Carriage requirements for AIS
- Designed to meet new advanced communication modes, as defined by ITU-R.M.2092-1 for VDES
- Meets IEC standard for cyber security of navigation and radio communication systems
- Dual IEC 61162-450 network interfaces
- Built-in multi GNSS receiver
- CDU with waterproof front for exposed panel mount installations
- Versatile installation options

Options

- Type approved DGNSS add-on kit
- Saab Secure encrypted communication
- STANAG 4668 compatibility (warship AIS)
- Hot-Standby redundancy

Technical specifications

Dimensions/Weight

R6 Supreme transponder	250x180x50 mm / 2000g
R6 Junction Box	250x180x50 mm / 900g
R6 Supreme CDU	220x125x45 mm / 1500g

Interfaces

IEC 61162-1/2	4 Sensor/LR input/output
	3 ECDIS/ARPA/Pilot plug
LAN	2 IEC 61162-450 Eth. RJ45

Radio Module

VHF Transmitter	1 W – 12.5 W
Channel Bandwidth	25, 50, 100, 150 kHz
Receiver Sensitivity	Better than -118 dBm (AIS)
Number of Rx processes	Up to 64 parallel
Frequencies	156.025 – 162.025 MHz

AIS functionality

AIS, LR AIS	IEC 61993-2
ASM	ITU-R.M.1371-5
AMRD	IEC 63343 PAS
	ITU-R.M.2135

Bridge alert mgmt

	IEC 62923-1/-2
--	----------------

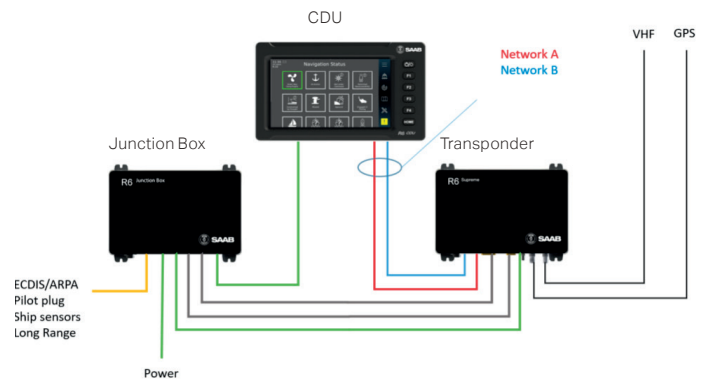

Environmental

R6 Supreme transponder	IEC 60945 Protected
R6 Junction Box	IEC 60945 Protected
R6 Supreme CDU	IEC 60945 Protected

Power input

Input voltage	12-24 VDC Nominal
---------------	-------------------

Power consumption

R6 Supreme transponder	15 Watts
R6 Supreme CDU	5 Watts

Recommended fuse size

	10 Amp. Slow blow fuse/breaker
--	--------------------------------

VHF Antenna

	50 Ohm (BNC)
--	--------------

GNSS Antenna

	50 Ohm (TNC), 5 VDC
--	---------------------

Cyber security

	IEC 63154, IEC 61162-460 (under implementation)
--	---